

NO.	REV. BY	DESCRIPTION	DATE

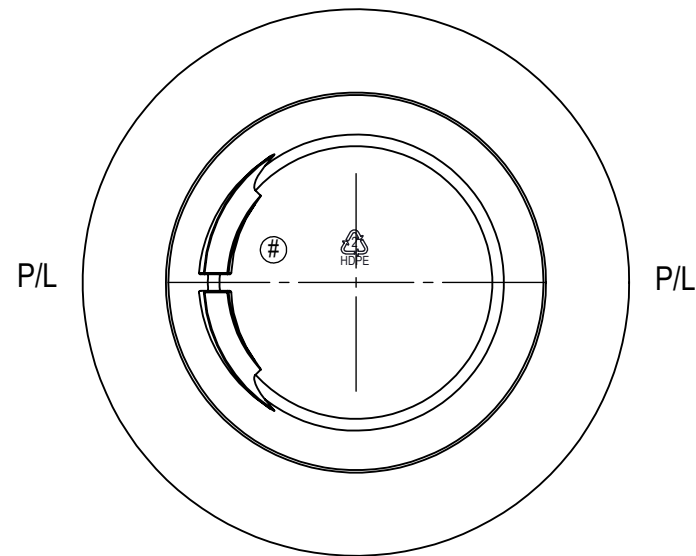

BOTTLE SPECIFICATIONS			
MATERIAL: HDPE	FILL CAPACITY: 1250 ML ± 20ML		
WEIGHT: 58g ± 2g	O/F CAPACITY:		
NECK SPECIFICATIONS			
FINISH	63-400 SPECIAL	"A" DIM.	N/A
STYLE	M	"B" DIM.	N/A
"T" DIM.	$\text{Ø } 2.444 \pm .017$	HELIX ANG.	1° 13'
"E" DIM.	$\text{Ø } 2.350 \pm .017$	T.P.I	6
"I" DIM.	N/A	PITCH	.167
"D" DIA.	N/A	CUTTER DIA.	.500
"H" DIM.	$.474 \pm .015$	THREAD TURNS	1
"S" DIM.	$.046 \pm .015$		

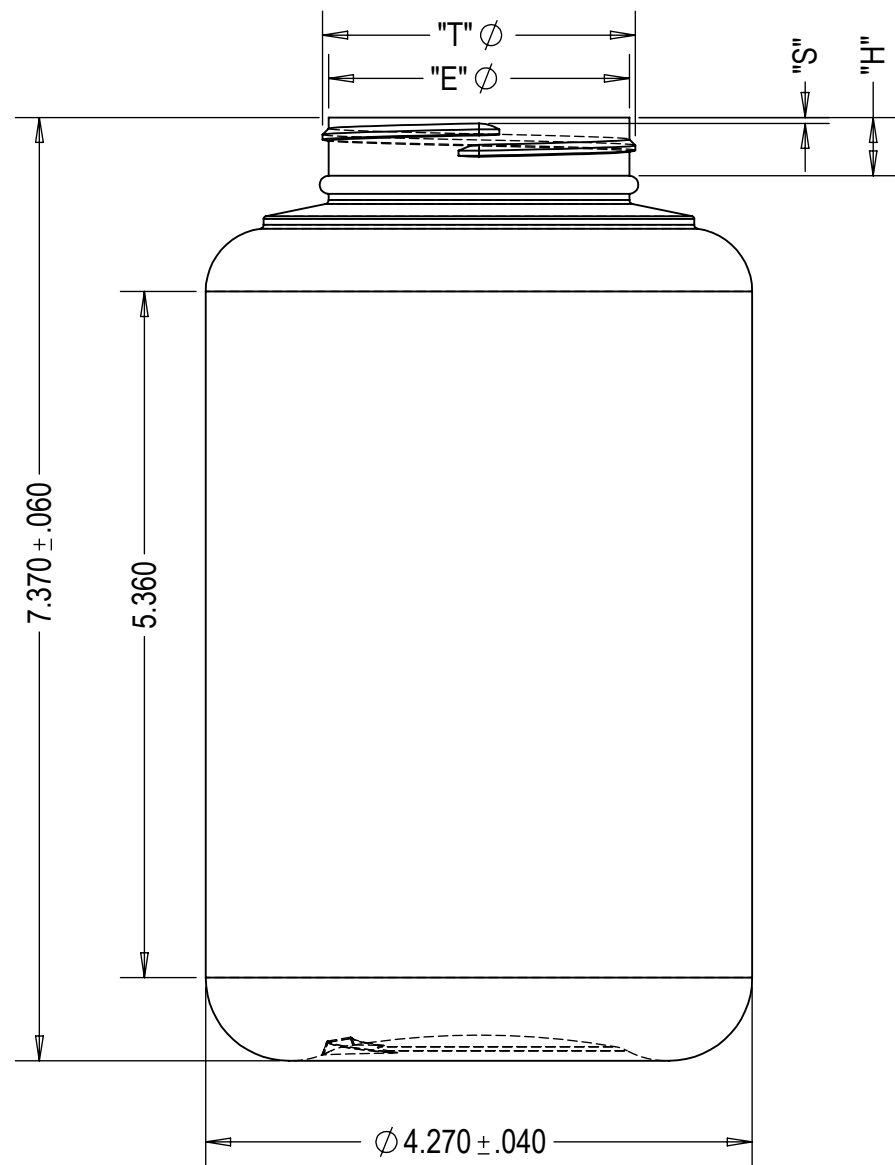

DWN. BY: A.P	DATE: 01/08/19	DESCRIPTION: 1250 ML JAR 63MM
APR. BY:	DATE:	DRAWING NO.:
SCALE: 1:1		