

NO.	REV. BY	DESCRIPTION	DATE

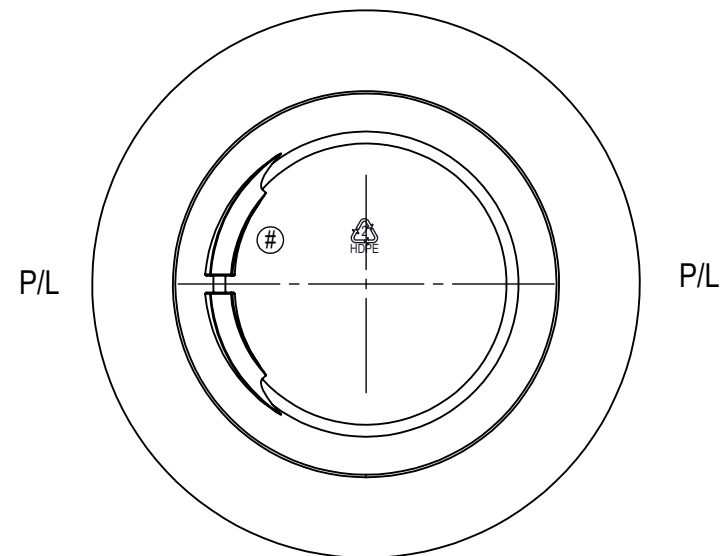

BOTTLE SPECIFICATIONS			
MATERIAL: HDPE		FILL CAPACITY: 1250ML ± 20ML	
WEIGHT: 58g ± 2g		O/F CAPACITY:	
NECK SPECIFICATIONS			
FINISH	89 MM PANO	"A" DIM.	3.450 ± .017
STYLE	M	"B" DIM.	3.550 ± .017
"T" DIM.	Ø 3.493 ± .017	HELIX ANG.	1 ° 4'
"E" DIM.	Ø 3.373 ± .017	T.P.I	5
"I" DIM.	N/A	PITCH	.200
"D" DIA.	.920 MIN	CUTTER DIA.	.500
"H" DIM.	.608 ± .015	THREAD TURNS	1
"S" DIM.	.060 ± .015		

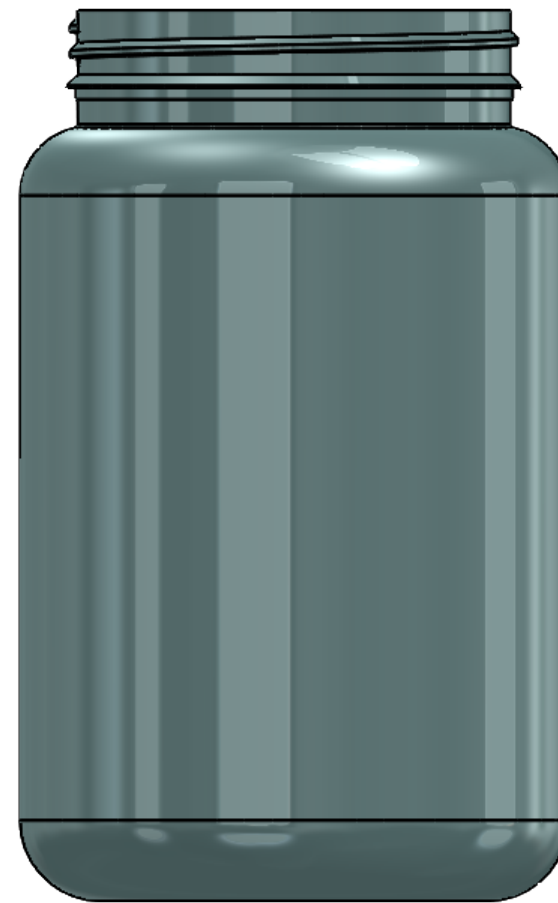
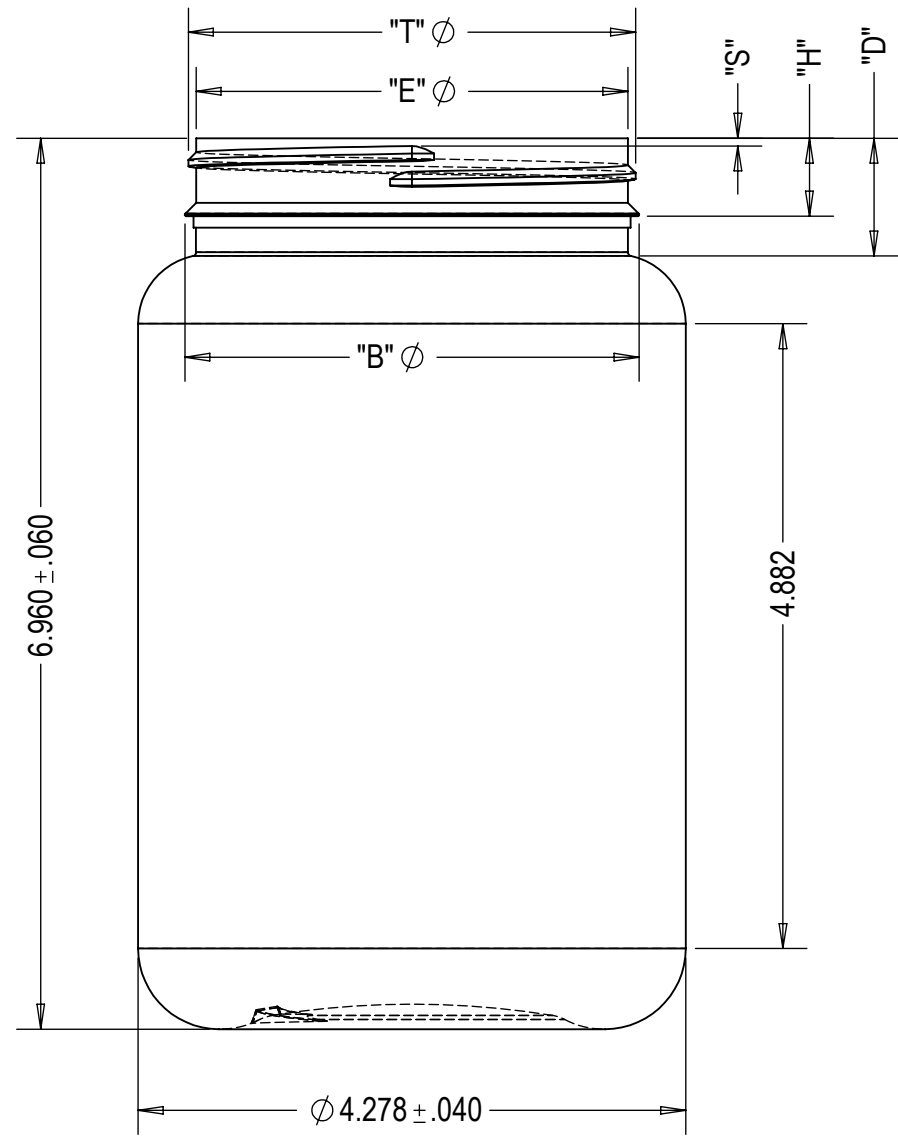

DWN. BY: A.P	DATE: 01/08/19	DESCRIPTION:	1250 ML JAR
APR. BY:	DATE:	DRAWING NO.:	
SCALE: 1:1			