

NO.	REV. BY	DESCRIPTION	DATE

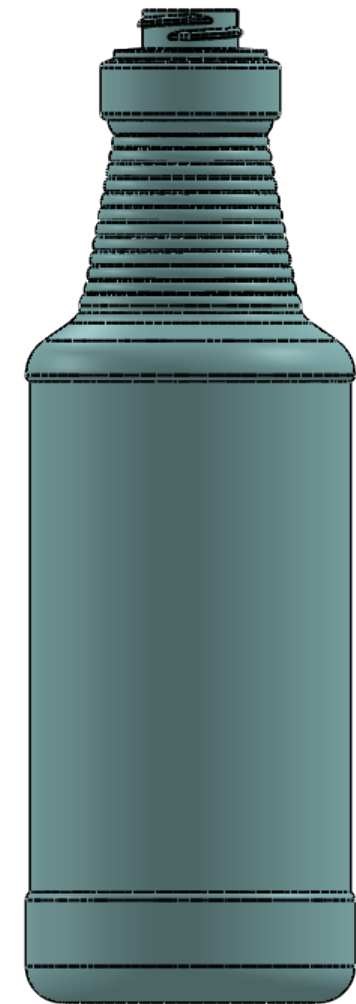

BOTTLE SPECIFICATIONS			
MATERIAL: HDPE	FILL CAPACITY: 1000 ML ± 15ML		
WEIGHT: 56g ± 3g	O/F CAPACITY:		
NECK SPECIFICATIONS			
FINISH	28-400	"L" DIM.	N/A
STYLE	M	"W" DIM.	N/A
"T" DIM.	Ø 1.078 ± .010	HELIX ANG.	2°57
"E" DIM.	Ø .984 ± .010	T.P.I	6
"I" DIM.	N/A	PITCH	.167
BEAD DIA.	N/A	CUTTER DIA.	.500
"H" DIM.	.400 ± .015	THREAD TURNS	1
"S" DIM.	.046 ± .015		

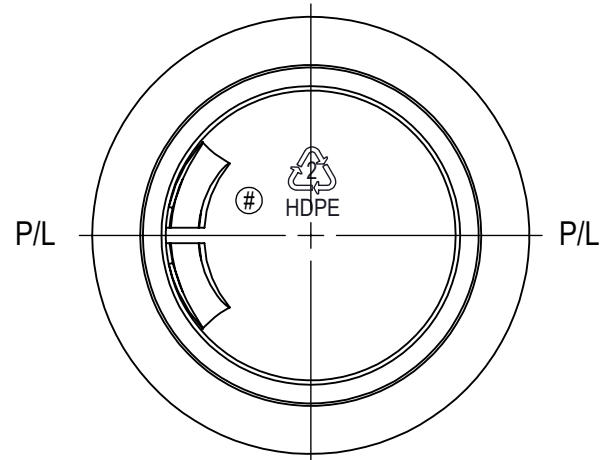
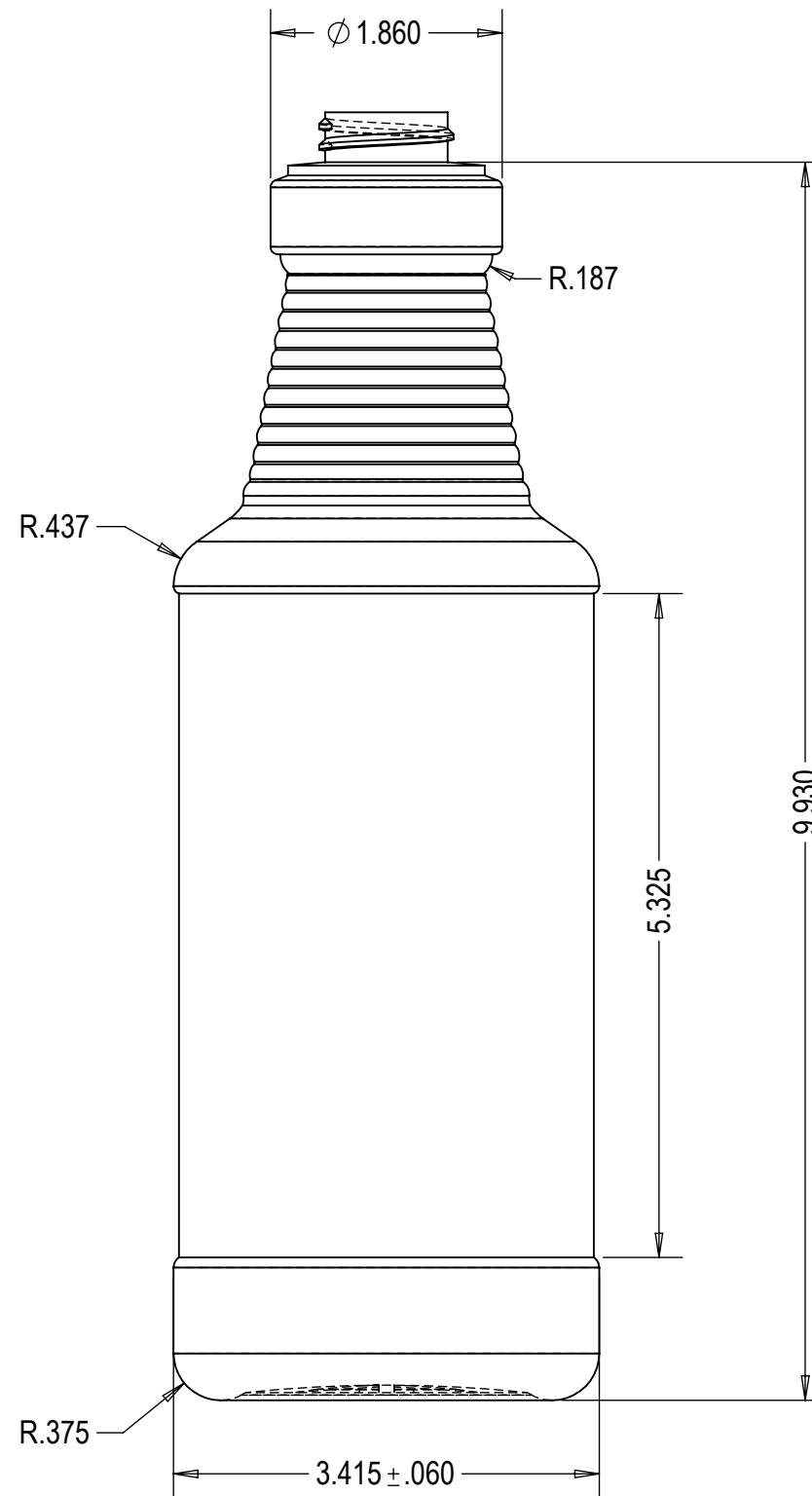
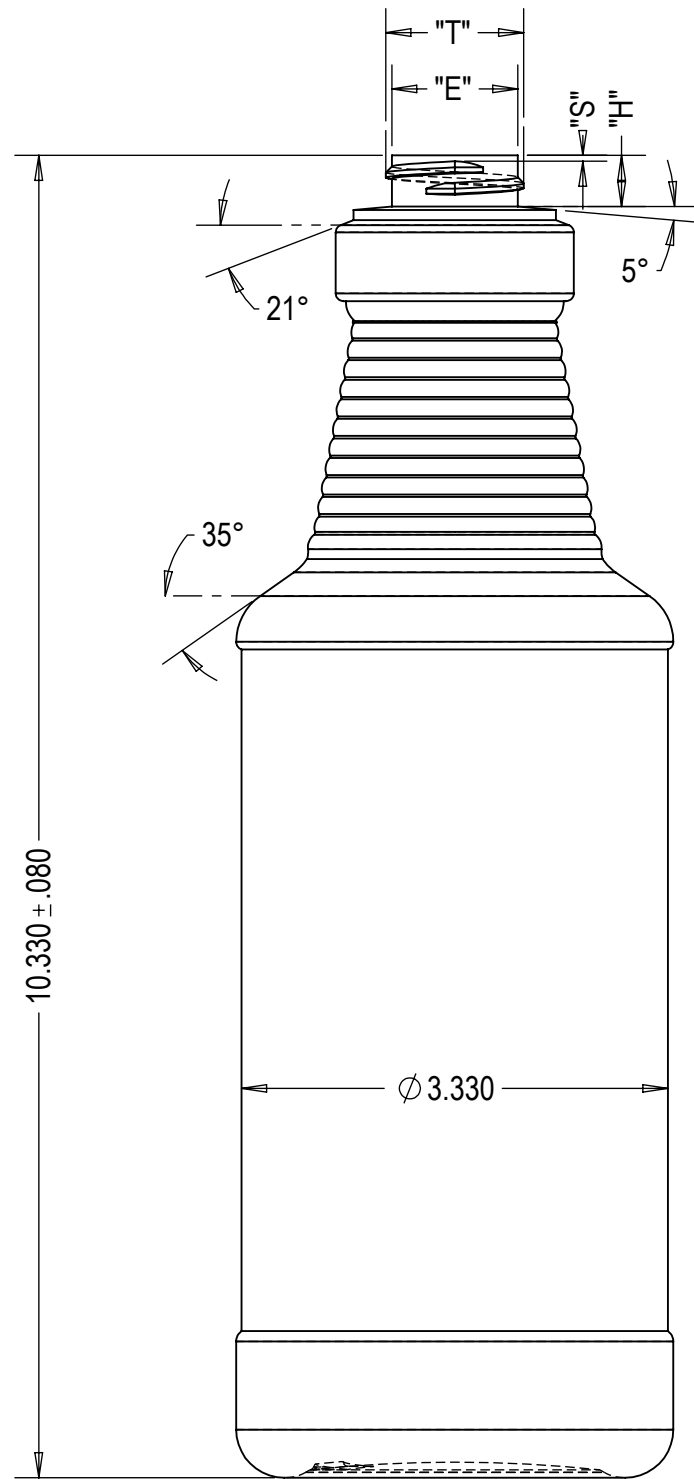

DWN. BY: A.P	DATE: APR 05/24	DESCRIPTION: 1 LT CARAFE 28-400
APR. BY:	DATE:	DRAWING NO.:
SCALE: 1:1		