

NO.	REV. BY	DESCRIPTION	DATE

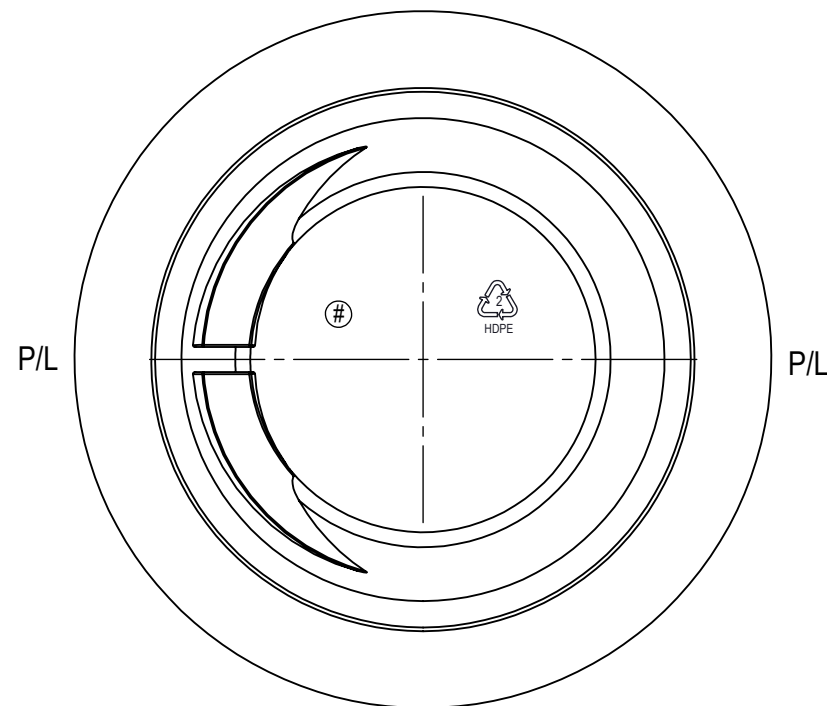

BOTTLE SPECIFICATIONS			
MATERIAL: HDPE	FILL CAPACITY:		
WEIGHT: 40g ± 2g	O/F CAPACITY: 620 ML ± 13ML		
NECK SPECIFICATIONS			
FINISH	89 MM PANO	"A" DIM.	3.450 ± .017
STYLE	M	"B" DIM.	3.550 ± .017
"T" DIM.	$\phi 3.493 \pm .017$	HELIX ANG.	1 °4'
"E" DIM.	$\phi 3.373 \pm .017$	T.P.I	5
"I" DIM.	N/A	PITCH	.200
"D" DIA.	.800 MIN	CUTTER DIA.	.500
"H" DIM.	.608 ± .015	THREAD TURNS	1
"S" DIM.	.060 ± .015		

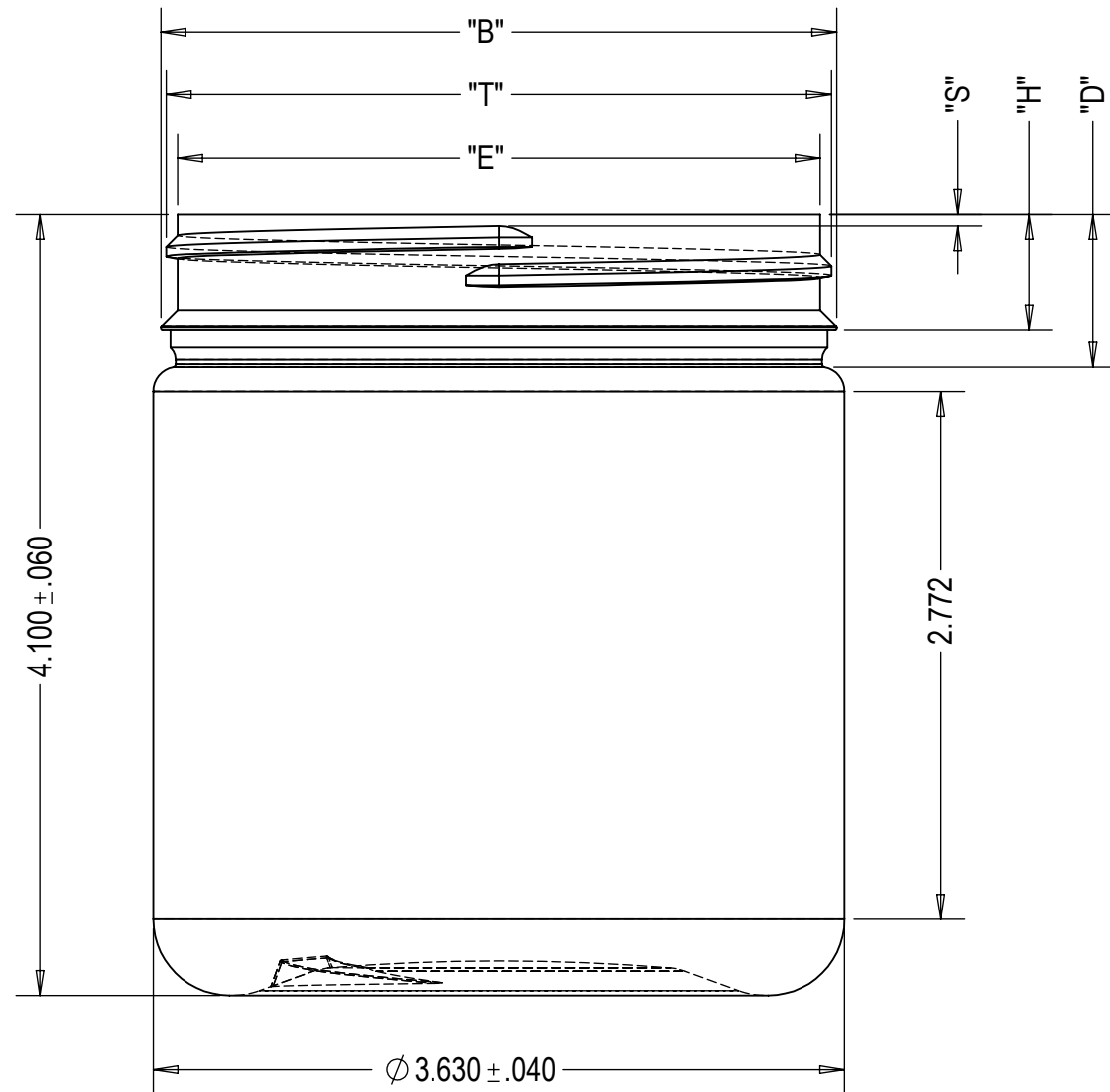

DWN. BY: A.P	DATE: 09/05/13	DESCRIPTION:	500 ML JAR
APR. BY:	DATE:	DRAWING NO.:	C93-4051-1-1A
SCALE: 1:1			