

NO.	REV. BY	DESCRIPTION	DATE

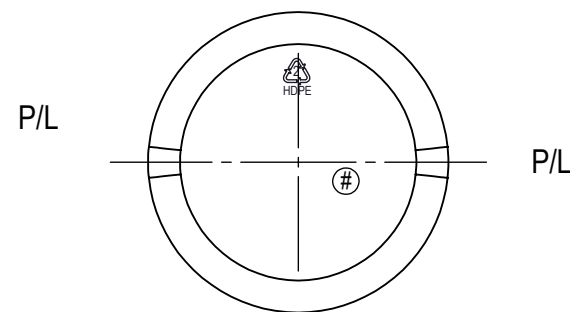

BOTTLE SPECIFICATIONS			
MATERIAL: HDPE	FILL CAPACITY: 532 ML ± 13ML		
WEIGHT: 32g ± 2g	O/F CAPACITY: 548 ML ± 13ML		
NECK SPECIFICATIONS			
FINISH	M24 SP410	"L" DIM.	.437
STYLE	M	"W" DIM.	N/A
"T" DIM.	∅ .932 ± .010	HELIX ANG.	2°34
"E" DIM.	∅ .848 ± .010	T.P.I	8
"I" DIM.	N/A	PITCH	.125
BEAD DIA.	N/A	CUTTER DIA.	.375
"H" DIM.	.646 ± .015	THREAD TURNS	2
"S" DIM.	.046 ± .015		

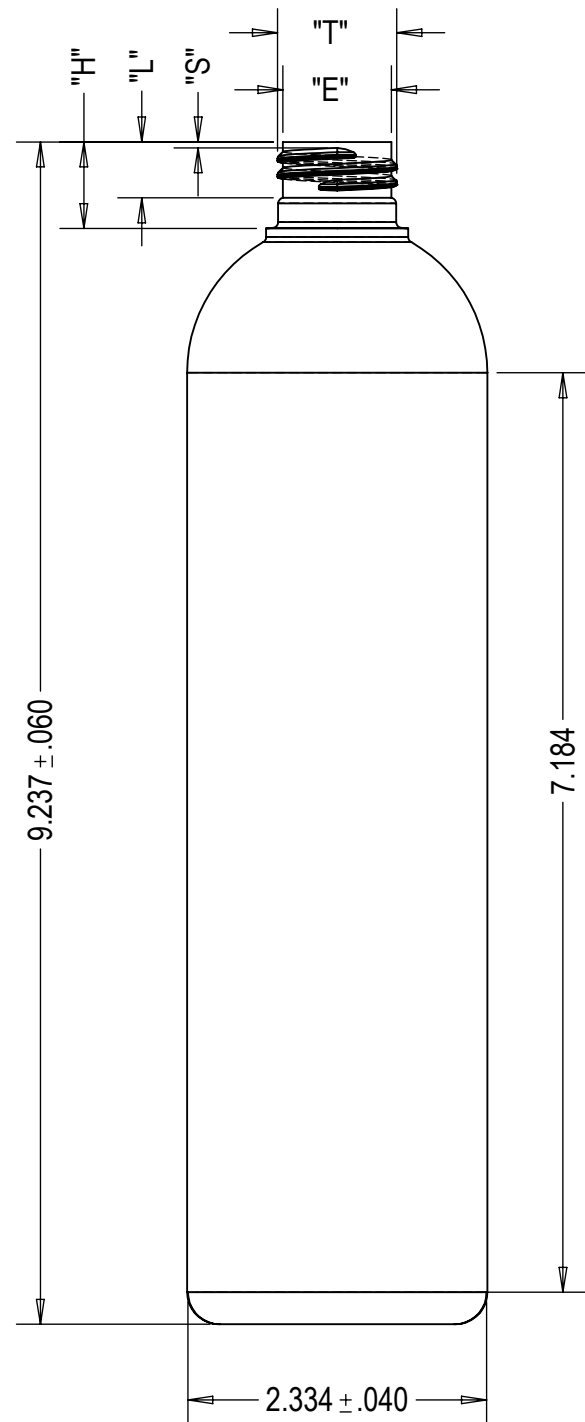

DWN. BY: A.P	DATE: 09/24/12	DESCRIPTION:	18 OZ BOSTON ROUND
APR. BY:	DATE:	DRAWING NO.:	C93-4028-1-1B
SCALE: 2:3			