

NO.	REV. BY	DESCRIPTION	DATE

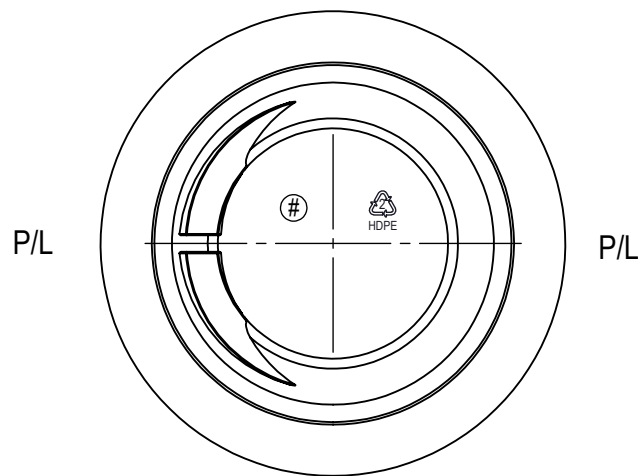

BOTTLE SPECIFICATIONS			
MATERIAL: HDPE	FILL CAPACITY: 750 ML \pm 15ML		
WEIGHT: 44g \pm 2g	O/F CAPACITY: 927 ML \pm 15ML		
NECK SPECIFICATIONS			
FINISH	89-400	"A" DIM.	3.450 \pm .017
STYLE	M	"B" DIM.	3.550 \pm .017
"T" DIM.	$\phi 3.503 \pm .017$	HELIX ANG.	1° 4'
"E" DIM.	$\phi 3.382 \pm .017$	T.P.I	5
"I" DIM.	N/A	PITCH	.200
"D" DIA.	N/A	CUTTER DIA.	.500
"H" DIM.	.535 \pm .015	THREAD TURNS	1
"S" DIM.	.051 \pm .015		

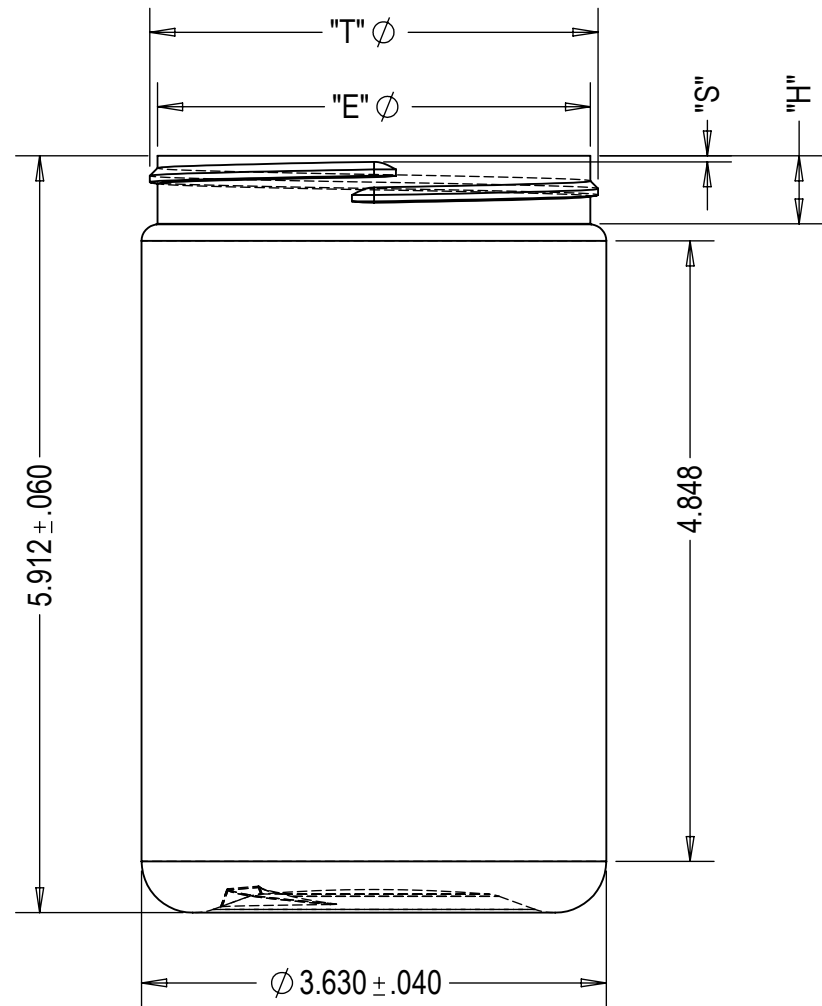

DWN. BY: A.P	DATE: 07/17/17	DESCRIPTION:	750 ML JAR
APR. BY:	DATE:	DRAWING NO.:	C93-4052-1-1A
SCALE: 1:1			