

NO.	REV. BY	DESCRIPTION	DATE

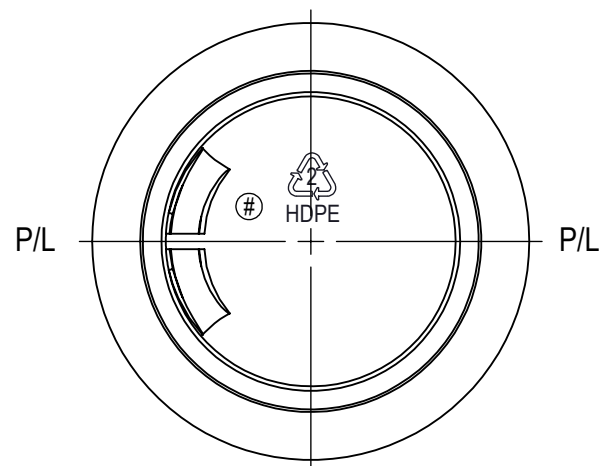

BOTTLE SPECIFICATIONS			
MATERIAL: HDPE	FILL CAPACITY: 946 ML $\pm$ 12ML		
WEIGHT: 53g $\pm$ 3g	O/F CAPACITY:		
NECK SPECIFICATIONS			
FINISH	24-410	"L" DIM.	N/A
STYLE	M	"W" DIM.	N/A
"T" DIM.	$\phi .932 \pm .008$	HELIX ANG.	$2^\circ 57'$
"E" DIM.	$\phi .848 \pm .008$	T.P.I	6
"I" DIM.	N/A	PITCH	.167
BEAD DIA.	N/A	CUTTER DIA.	.500
"H" DIM.	.646 $\pm$ .015	THREAD TURNS	1.5
"S" DIM.	.046 $\pm$ .015		

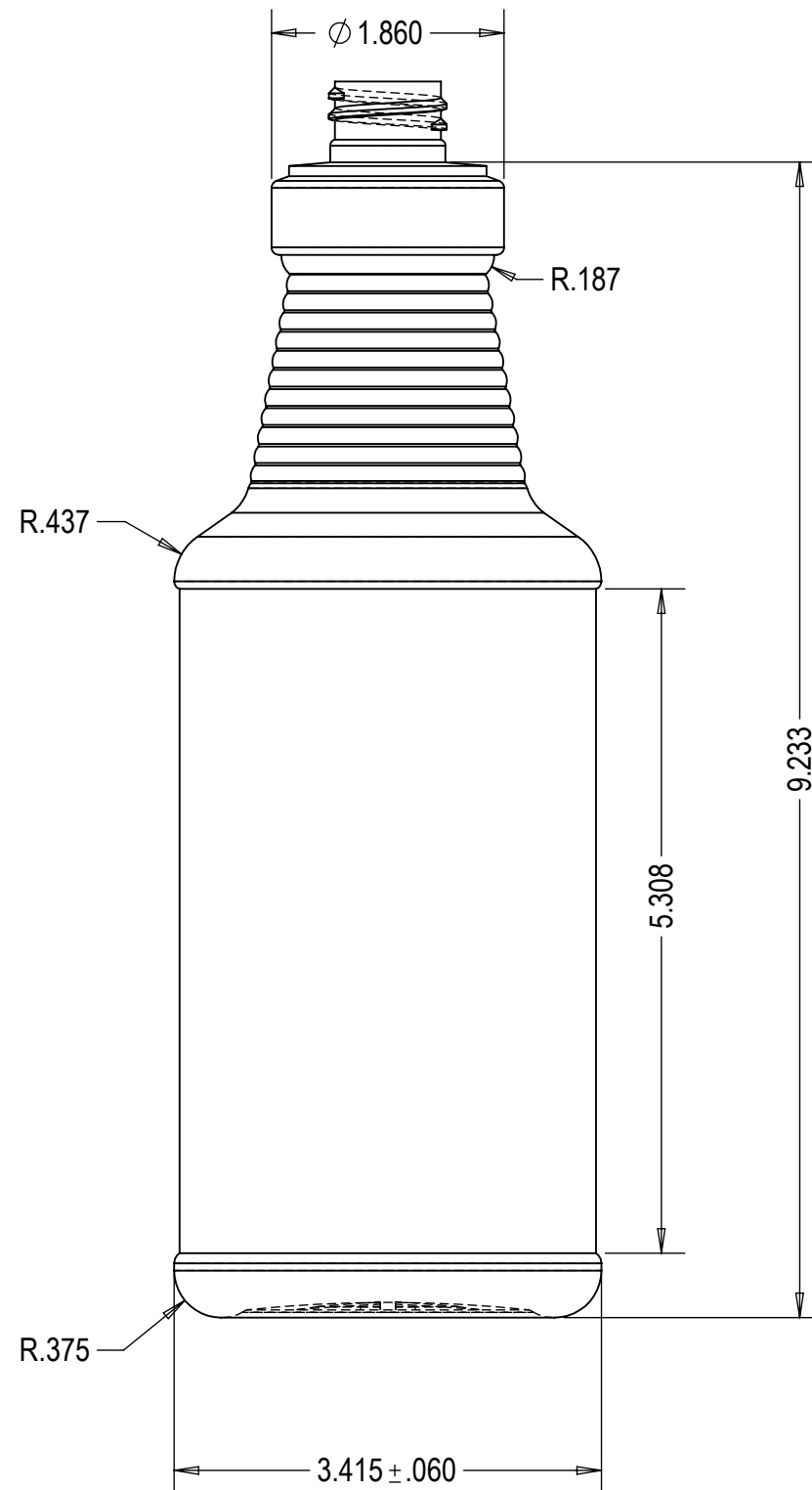
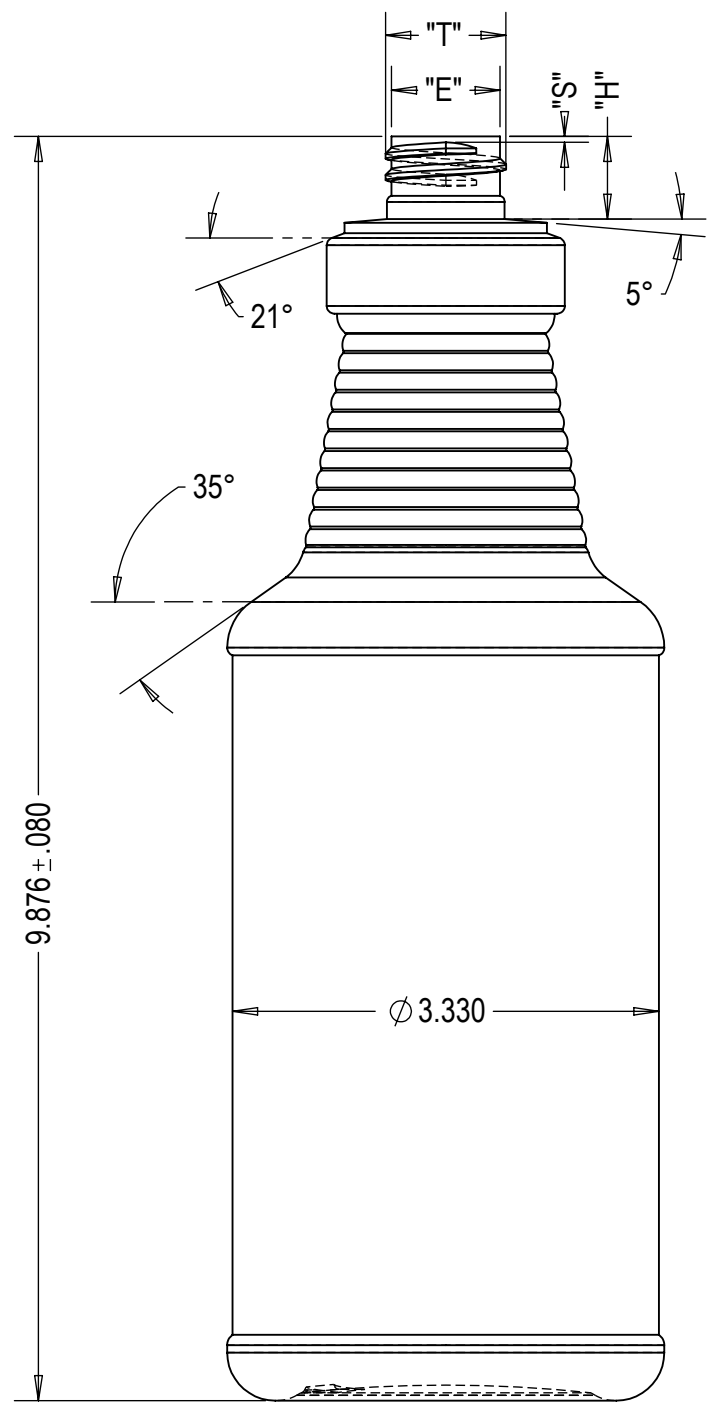

DWN. BY: A.P	DATE: APR 05/24	DESCRIPTION: 32 OZ CARAFE 24-410
APR. BY:	DATE:	DRAWING NO.:
SCALE: 1:1		