

NO.	REV. BY	DESCRIPTION	DATE

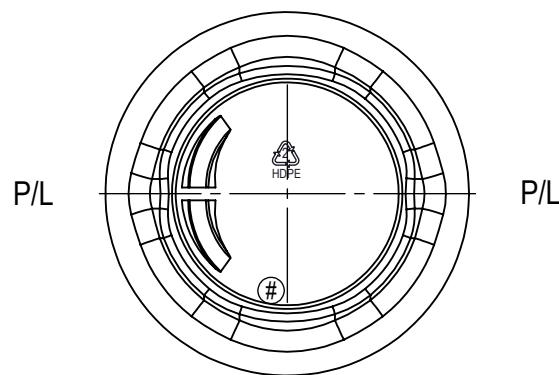

BOTTLE SPECIFICATIONS			
MATERIAL: HDPE	FILL CAPACITY: 500 ML ± 11ML		
WEIGHT: 34g ± 2g	O/F CAPACITY: 522 ML ± 11ML		
NECK SPECIFICATIONS			
FINISH	M24 SP410	"L" DIM.	.437 MIN
STYLE	M	"W" DIM.	N/A
"T" DIM.	Ø .932 ± .010	HELIX ANG.	2°34'
"E" DIM.	Ø .848 ± .010	T.P.I	8
"I" DIM.	N/A	PITCH	.125
BEAD DIA.	N/A	CUTTER DIA.	.375
"H" DIM.	.646 ± .015	THREAD TURNS	2
"S" DIM.	.046 ± .015		

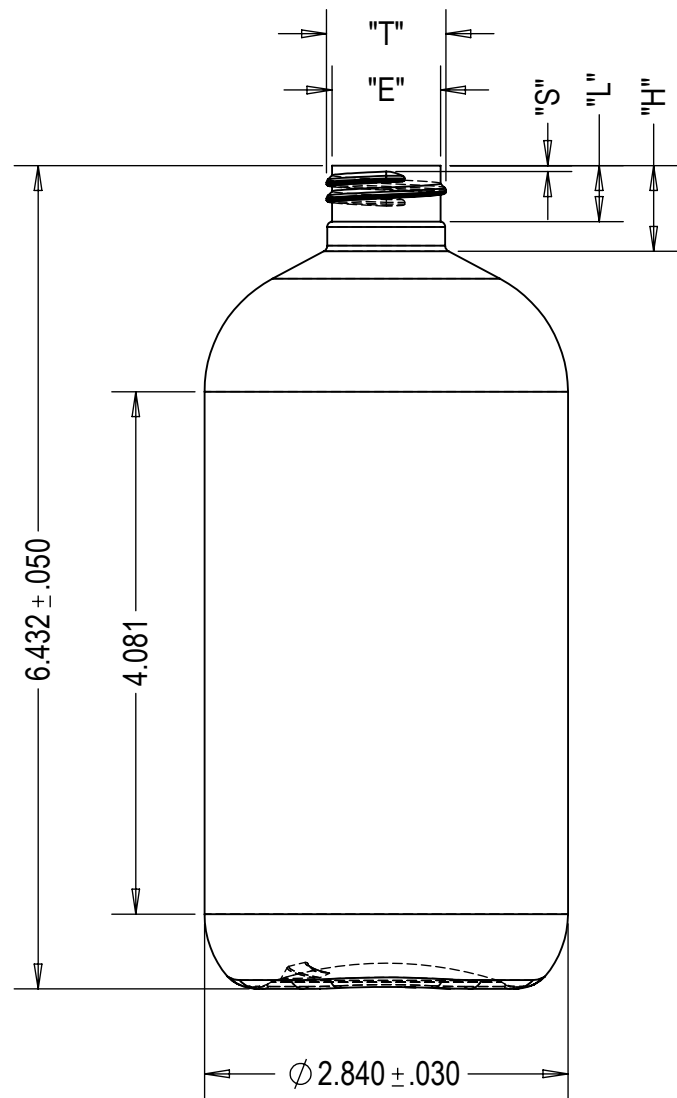

DWN. BY: A.P	DATE: 03/25/19	DESCRIPTION: 500 ML BOSTON ROUND
APR. BY:	DATE:	DRAWING NO.: C93-4244-1-1A
SCALE: 2:3		