

NO.	REV. BY	DESCRIPTION	DATE

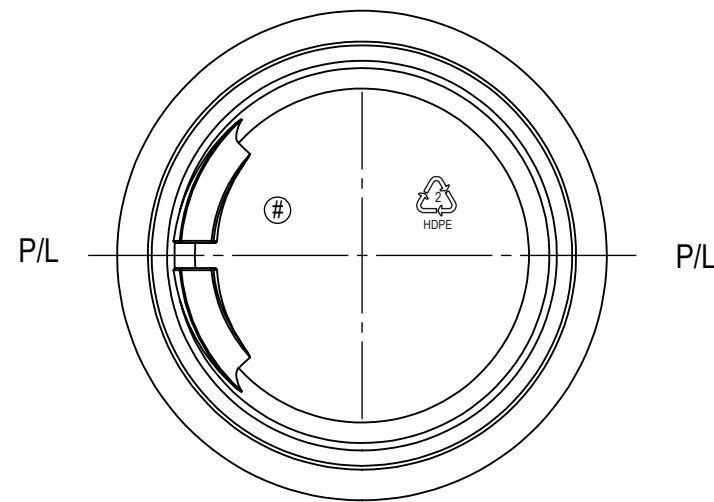

BOTTLE SPECIFICATIONS			
MATERIAL:	HDPE	FILL CAPACITY:	177 ML ± 6ML
WEIGHT:	19g ± 1g	O/F CAPACITY:	197 ML ± 6ML
NECK SPECIFICATIONS			
FINISH	63-400	"A" DIM.	N/A
STYLE	M	"B" DIM.	N/A
"T" DIM.	Ø 2.444 ± .017	HELIX ANG.	1° 13'
"E" DIM.	Ø 2.350 ± .017	T.P.I	6
"I" DIM.	N/A	PITCH	.167
"D" DIA.	N/A	CUTTER DIA.	.500
"H" DIM.	.408 ± .015	THREAD TURNS	1.25
"S" DIM.	.046 ± .015		

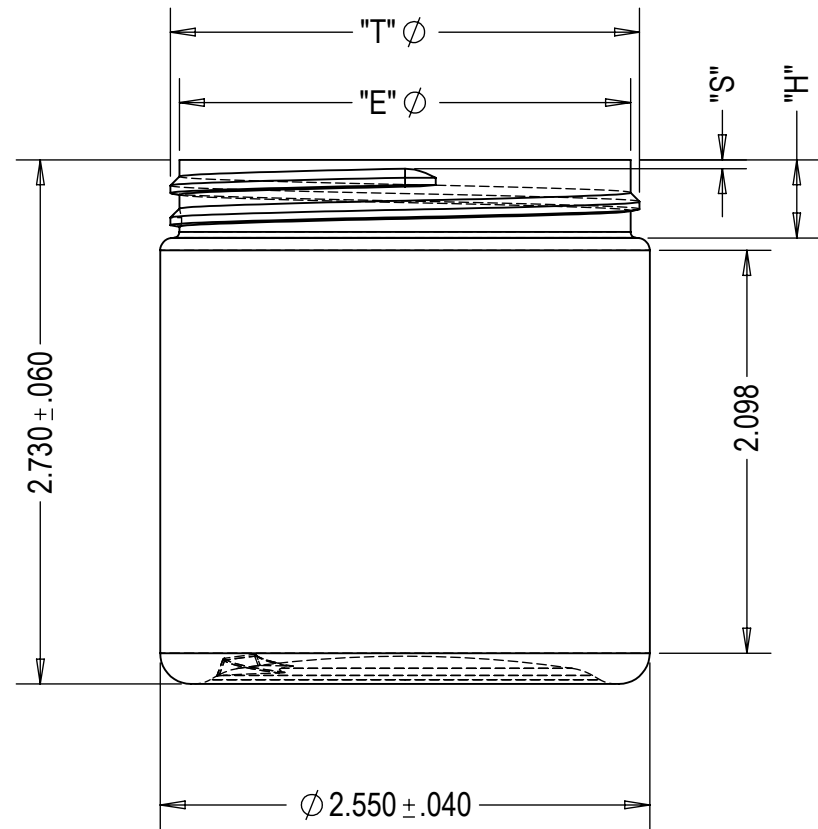

DWN. BY:	A.P	DATE:	09/10/15	DESCRIPTION:	6 OZ JAR(3)
APR. BY:		DATE:		DRAWING NO.:	C93-4123-2-1A
SCALE:	1:1				