

NO.	REV. BY	DESCRIPTION	DATE

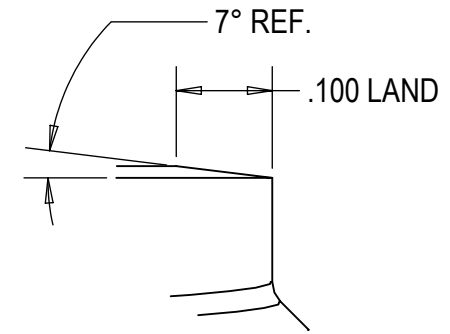

DETAIL A
SCALE 5 : 1

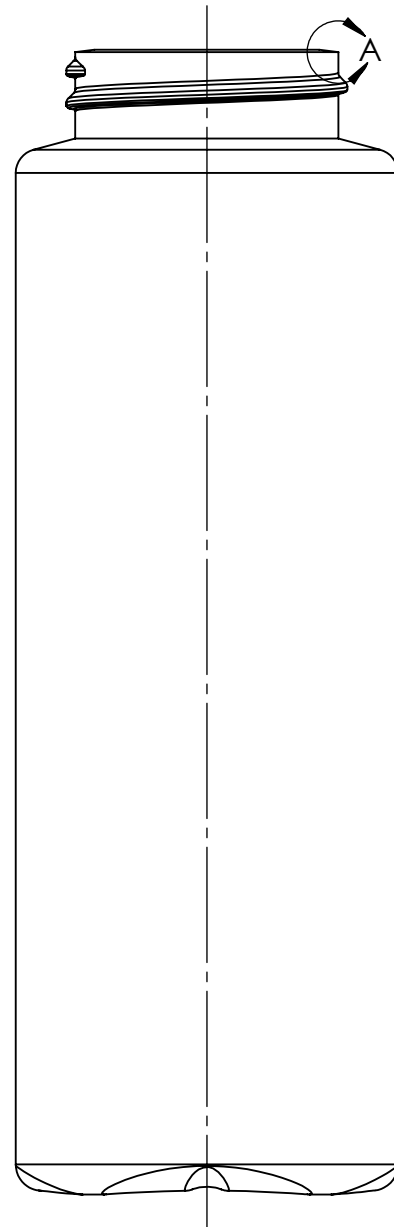
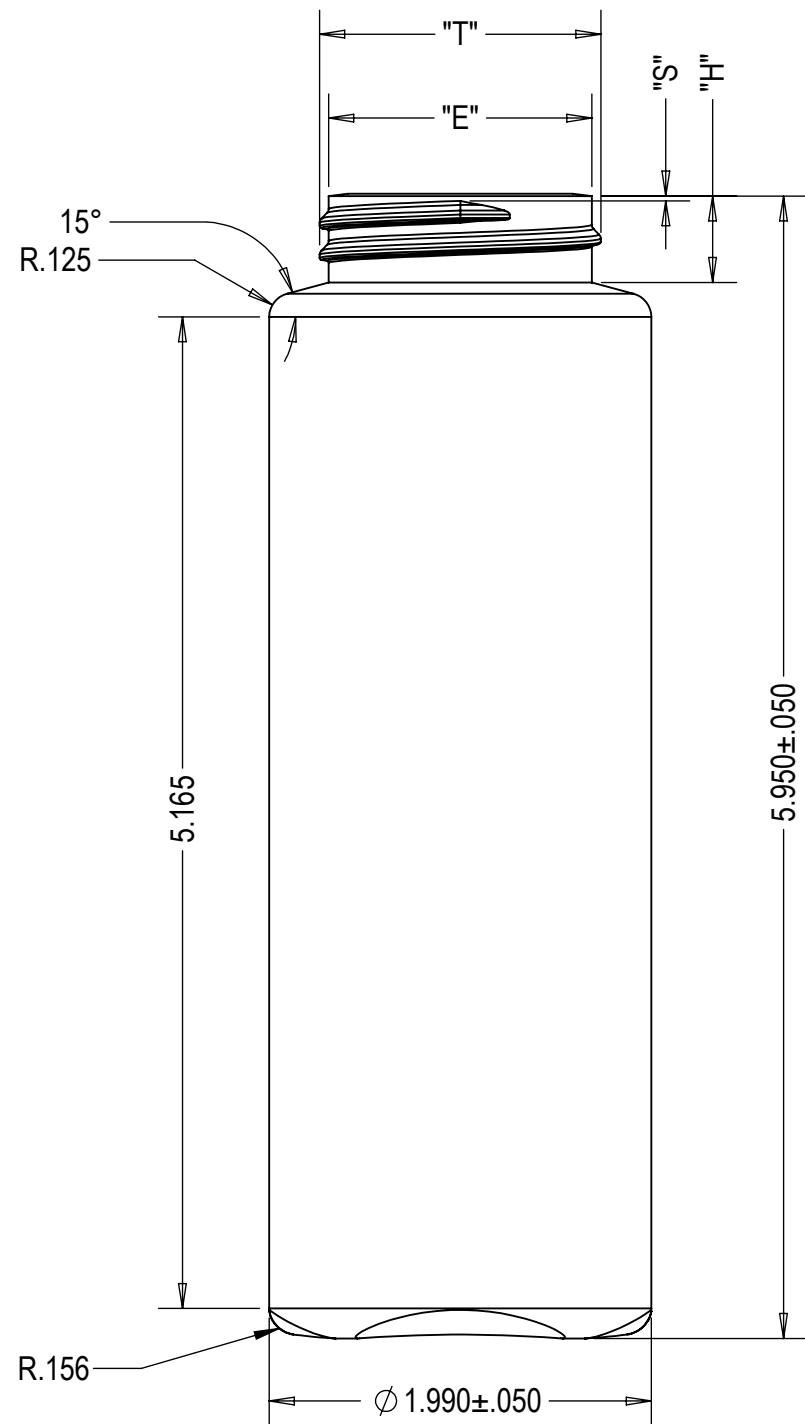
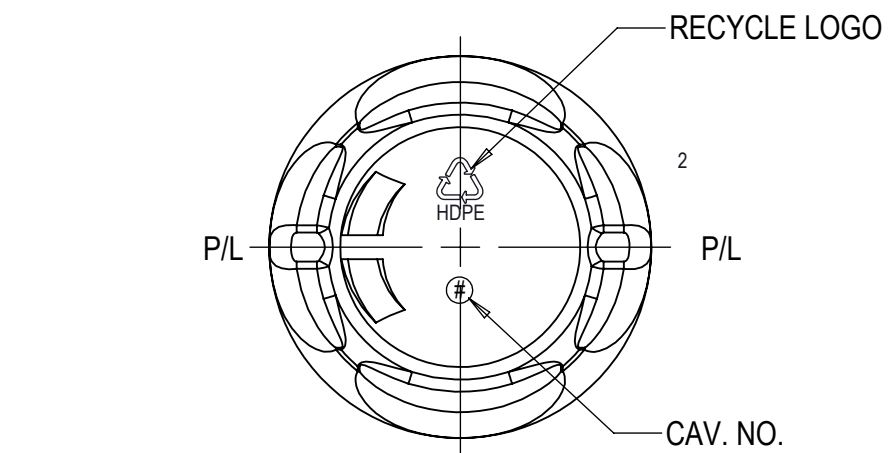

BOTTLE SPECIFICATIONS			
MATERIAL: HDPE	FILL CAPACITY: 250 ml ± 7 ml		
WEIGHT: 23g ± 2g	O/F CAPACITY: 263 ml ± 7 ml		
NECK SPECIFICATIONS			
FINISH	38-400	"L" DIM.	N/A
STYLE	M	"W" DIM.	N/A
"T" DIM.	Ø 1.464 ± .012	HELIX ANG.	2°9'
"E" DIM.	Ø 1.370 ± .012	T.P.I	6
"I" DIM.	N/A	PITCH	.137
BEAD DIA.	N/A	CUTTER DIA.	.500
"H" DIM.	.450 ± .015	THREAD TURNS	1.25
"S" DIM.	.025 ± .015		



DWN. BY: A.P	DATE: 05/26/22	DESCRIPTION: 250 ML CYLINDER
APR. BY:	DATE:	DRAWING NO.: C93-4312-1-1B
SCALE: 1:1		